

Interior Wall Installation:

Alstrong Wall Panels can be installed through various methods described below :

1. Wall Panels Installation with adhesive - No Groove
2. Wall Panels installation with adhesive - V Groove
3. Wall Panel installation with fixed clamps – No Groove



1. Wall Panels installation with adhesive – No Groove

Step 1:

Preparation: To achieve visually appealing facade and cost efficient installation, choose from standard sizes of Alstrong Wall Panel (U groove) with insulation, depending on the site requirement to minimize manual cutting at the site thereby saving on time.

Step 2:

Fix clamps on the wall with the help of 6 X 65 mm SS Fastener & maintain 600 mm distance between adjacent clamps both horizontally & vertically. Fix panel attached with insulation on to the clamps. Adjust clamps to maintain level between panels. Installation can start from the Lower corner from left or center depending on uniformity of the facade.

Step 3:

For filling joints between the two panels fill the gap with the help of Silicon or Epoxy based grouting. Repeat the process for further installing the panels.

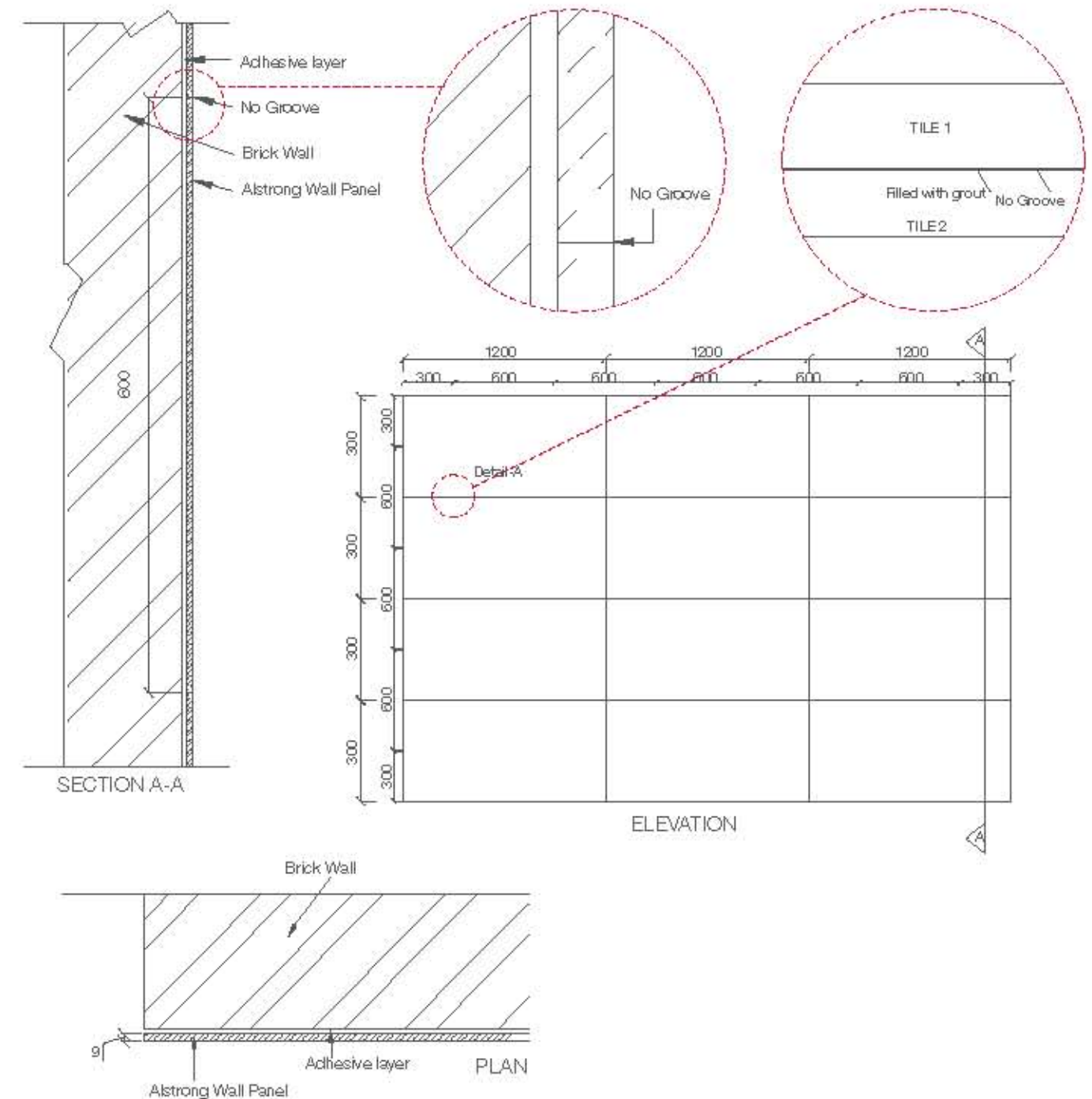
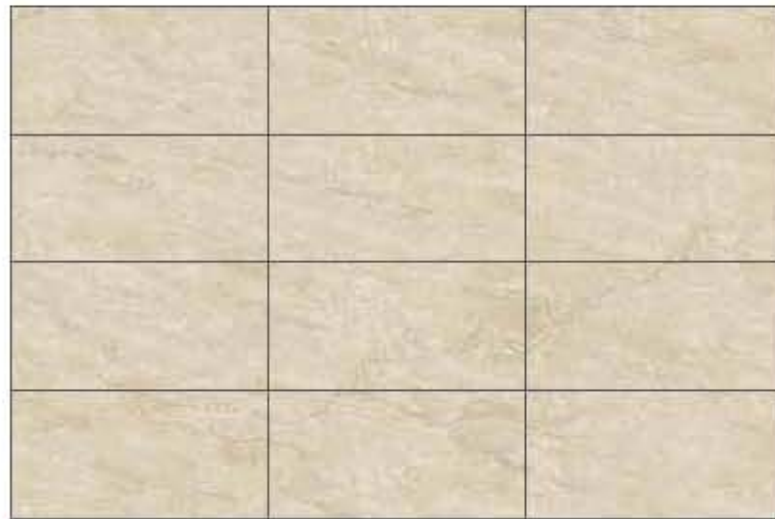

2. Wall Panels installation with adhesive – V Groove

Step 1:

Measure the wall area for deciding required Plank sizes .

Step 2.

Choose from standard sizes of Alstrong Wall Panel with V Groove as per the customer requirement.

Step 3.

Mix A & B glue together in 2:1 ratio. Apply the mixture on the sheet as shown in the diagram and sprinkle thick sand particle on the adhesive. Fix the sheet on the wall and hold it for 15 minutes.

Step 4.

Installation can be done with gap or without gap in between panels. In case installation is with gap at the jointing area between two panels fill it with Silicon or Epoxy Grouting or filler as per the requirements.

Repeat the above procedure for installing further panels.

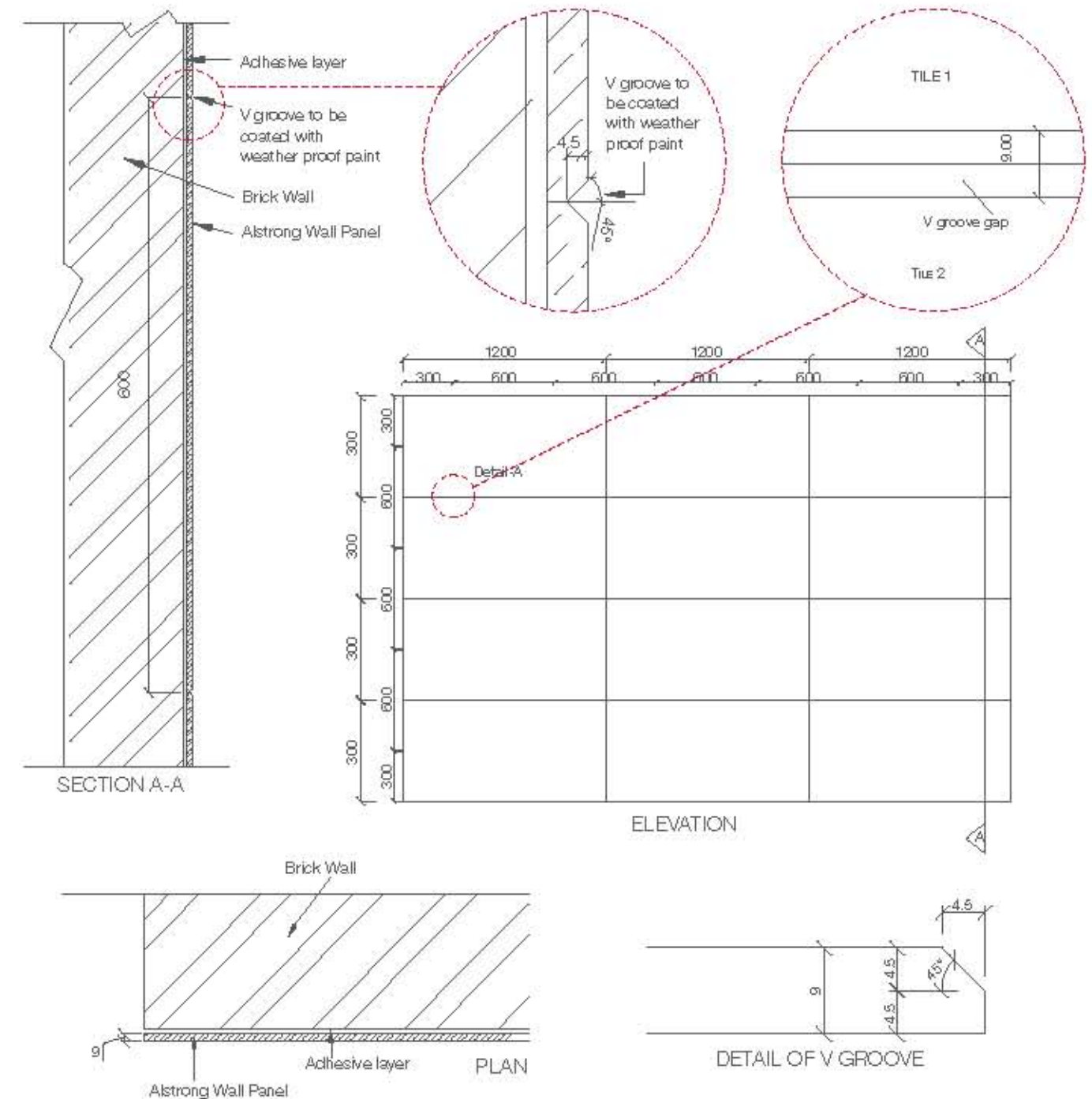

3. Wall Panels installation with fixed clamps - No groove

Step 1:

Preparation: To achieve visually appealing Wall and cost efficient installation, choose from standard sizes of Alstrong Wall Panels specially cut for non groove application, depending on the site requirement to minimize manual cutting at the site thereby saving on time.

Step 2:

Fix clamps on the wall with the help of 6 X 65 mm SS Fastener anchor bolt & maintain 600 mm distance between adjacent clamps both horizontally & vertically. In case of uneven surface align clamps with the help of washers so that level is maintained between the panels. Fix panel on to the clamps. Installation can start from the Lower corner from left or center depending on uniformity of the façade.

Step 3:

For filling joints between the two panels fill the gap with the help of Epoxy based grouting. Repeat the process for further installing the panels.

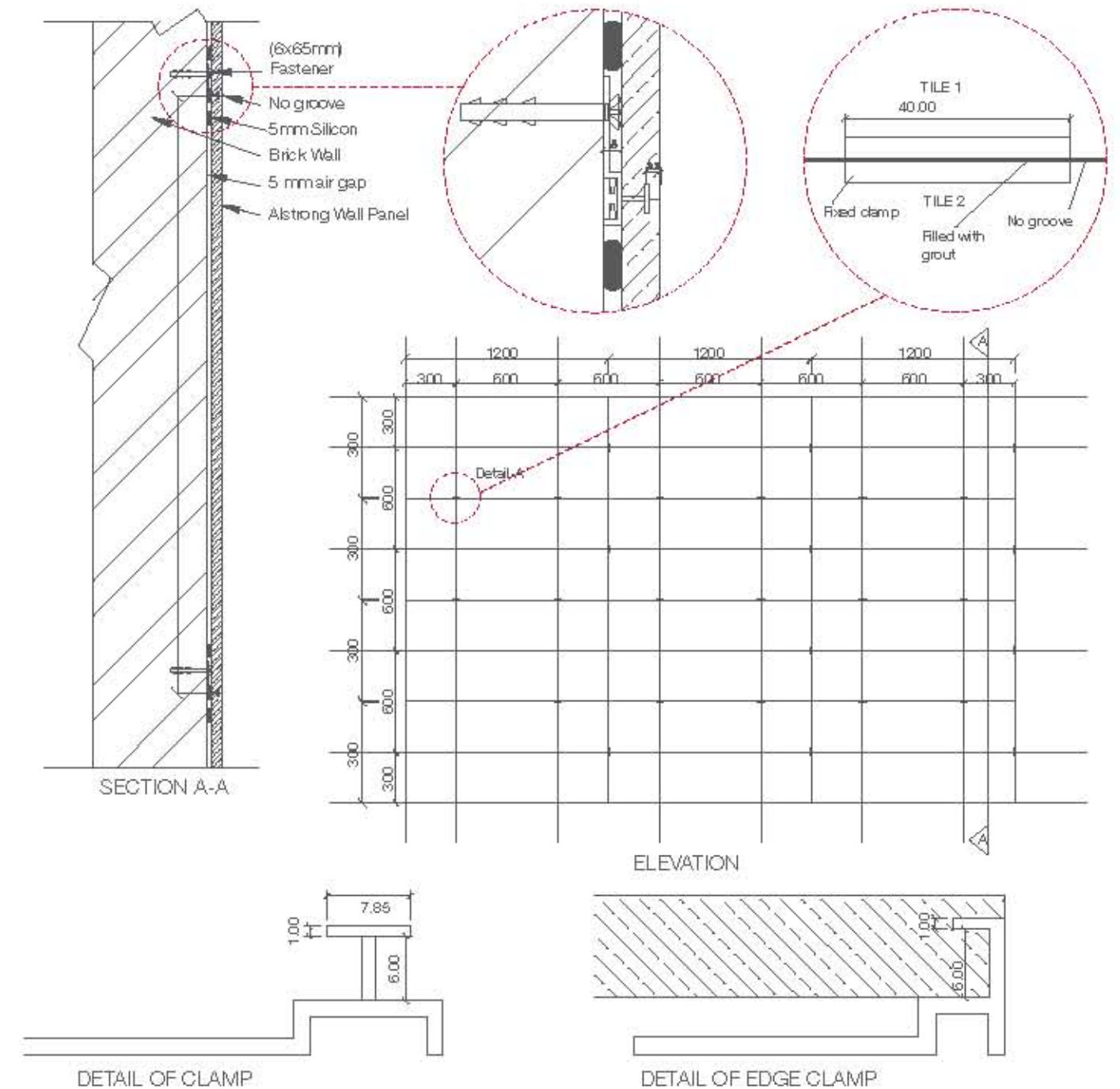

Corner Joint Detail

Internal Corner

Step 1:

Making of Groove: Prepare a groove of 9mm width and 4 mm depth as shown in the drawing on the front side of one sheet. Please use proper tool for this purpose to avoid any chipping.

Step 2:

Apply adhesive in the groove for stronger joint and insert un-cut sheet as shown in the drawing. Hold both the sheets in position for some time so that the adhesive hold them strongly.

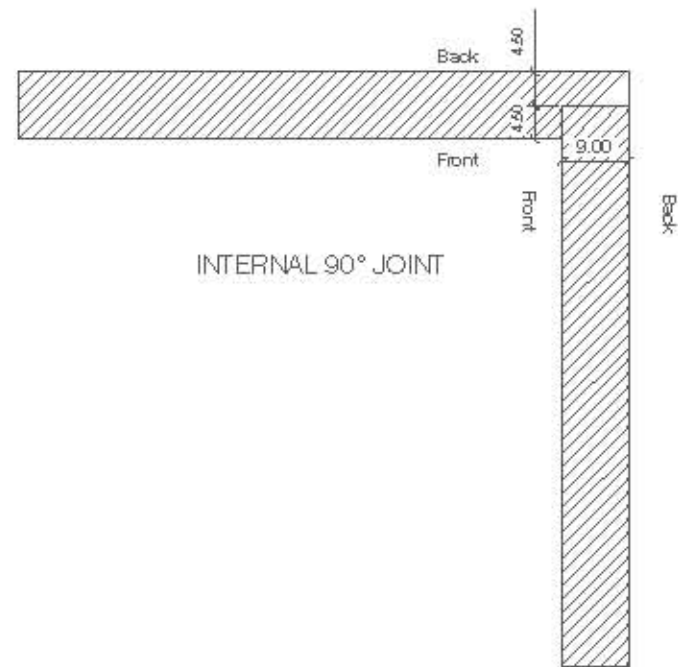

External Corner

Step 1:

Making of Groove: Prepare groove of 4 mm width and 4 mm depth as shown in the drawing on the front side of one sheet. Please use proper tool for this purpose to avoid chipping.

Step 2:

Apply adhesive in the groove for stronger joint and insert un-cut sheet as shown in the drawing. Hold both the sheets in position for some time so that the adhesive hold them strongly.

Step 3:

Fill weather silicon in the groove at the joint to finish the corner joint. Please make sure that you use masking tape on finished surface so that there is no spillage of silicon on the finished surface of Alstrong Wall Panel.

